

## LINCOflex Easy Grader

The LINCOflex Easy Grader is a competitively priced stand-alone grader of a robust design. The grader is supplied ready for operation, and all that is needed is a power cable and air supply. It's a compact machine that is easy to install and easy to move around.

Easy cleaning has been a focus-point in the construction of this machine. As an example, there are very few horizontal surfaces where water can collect.

The LINCOflex Easy Grader is ideal for weighing and sorting items up to 250 x 350 mm size and 4000 g weight. The capacity is up to 130 items/minute. The grader is controlled via a LINCOflex 500 control unit that is very simple to operate. Each level is protected by a password-function, and only functions that are required to run the machine are accessible.

The LINCOflex Easy Grader can be connected to the LINCOflex 2000 control software (not plug-and-play). The grader can also be connected to other, plant-specific control systems if required.

- *Accurate weighing*
- *Plug-and-play, easy installation (only with the LF 500 terminal option)*
- *Batching optional*
- *Robust and easy to clean*
- *User friendly and easy to maintain*
- *Low cost of ownership*

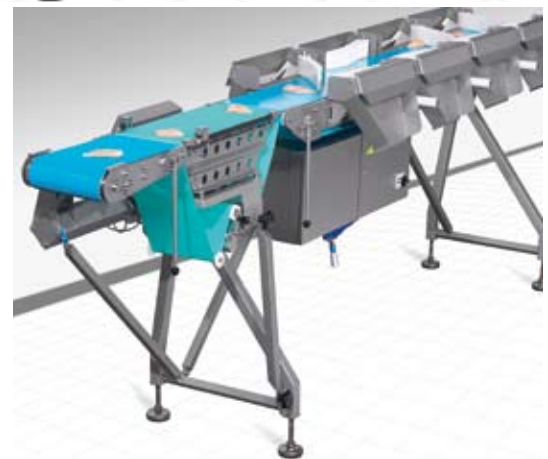
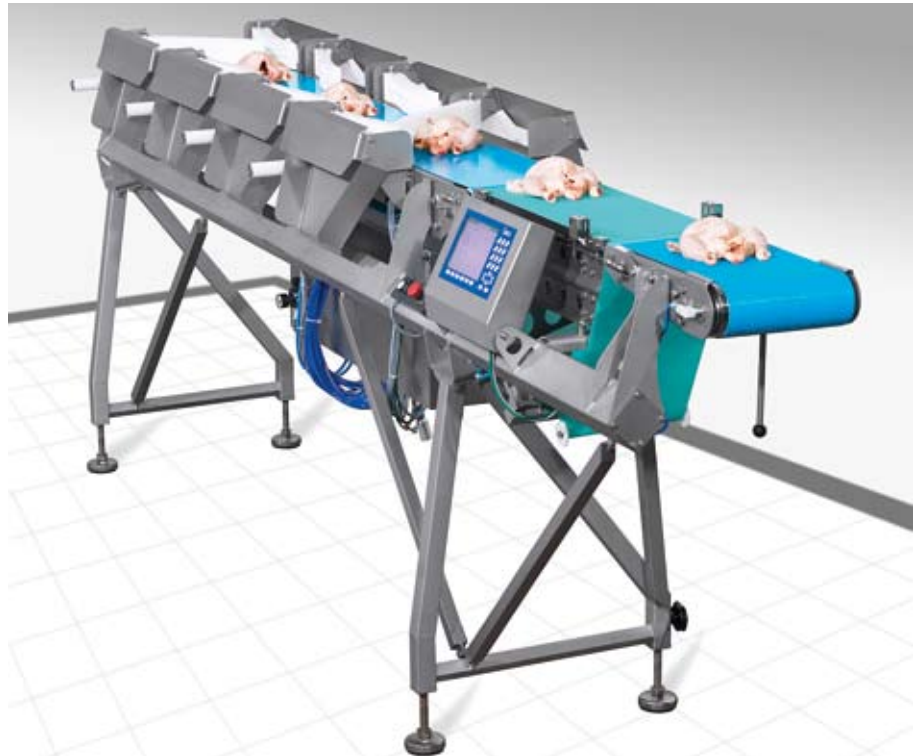

# TECHNICAL SPECIFICATION

A 17 736

Model/Type	Capacity ppm	Overall Dimension mm	Utilities				Machine Weight kg	Crated Weight kg	Crated Cube m3
			Connections	Consumption m <sup>3</sup> /H	Pressure Bar	Power kW			
7361	130	H = 1300 W = 700 L = 3990	3 x 400/480 V 10 A Air 1/4"	2.4	Min. 6 bar clean dry air	2	400	600	6.2

All specifications are subject to future modifications.

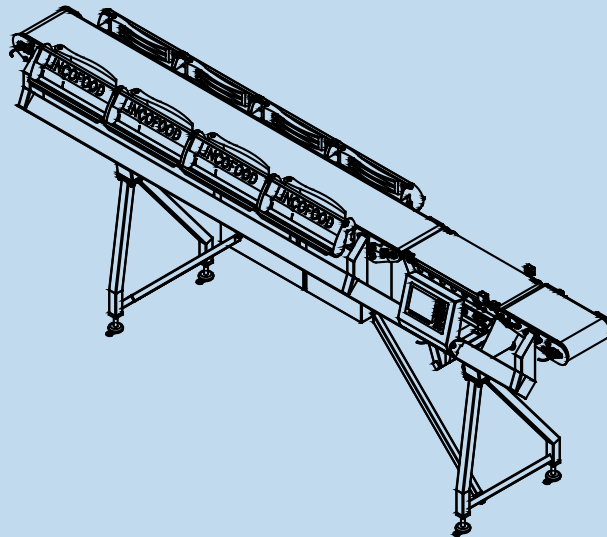
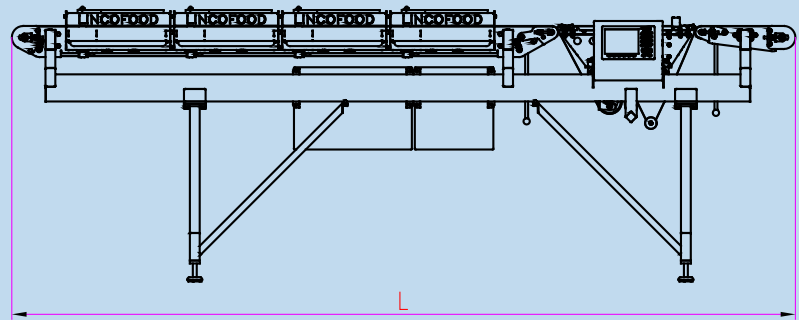
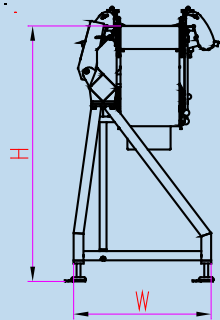

R 000160 01 02

LINCO FOOD SYSTEMS A/S  
DK-8380 Trige • Denmark  
Tel +45 86 23 14 55 • Fax +45 86 23 14 44  
linco@lincofood.com • www.lincofood.com

