

**BAADER 1377
Carcass Care® Killer**



Poultry of various sizes can be killed using the Baader 1377.

The Baader 1377 Killer can be adjusted quickly and easily, thus allowing the trouble-free adaptation to varying animal sizes.

The machine is arranged behind the stunner.

The stunned animals are conveyed head forward by means of guidance assemblies to the knife. During conveyance, the head is placed in cutting position so that a rotary cutter can perform the lateral cut with utmost precision. Damages to the windpipes can be prevented thanks to the precise adjustment.

Features and Benefits:

- Highly reliable
- Guidance assemblies quickly and easily adjustable
- Cutter precisely adjustable
- Easy to clean, operate and service
- Robust stainless steel construction
- Wear resisting

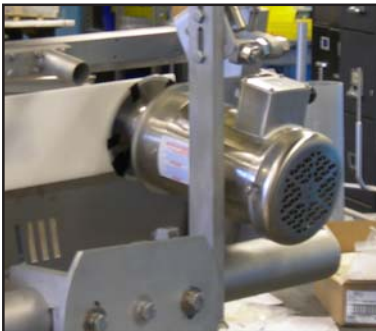

**Stainless Steel
Motor**



BAADER 1377 KILLER

• Technical Data

Operating Range		US	Metric
	Min	3 Lb	1.4 Kg
	Max	10 Lb	4.5 Kg

Note: The indicated limits of the working ranges may vary as a function of the proportion, quality and nutritional condition of the bird. In order to achieve an optimal result, the machine should be adjusted within its working range to the bird size principally processed.

Capacity	Min	50 bpm	(3,000 bph)
	Max	240 bpm	(14,400 bph)

Note: All others subject to approval by Baader-Johnson

Weights, Dimensions and Volume

Machine Weight:		300 Lb	150 Kg
Shipping Dims:	L	72"	1900 mm
	W	40"	1100 mm
	H	48"	1300 mm
Shipping Volume:		80 ft ³	2 m ³

Water

Process Water Reqs:	V	1 GPM	4 L/min
	P	40 PSI	3 bar
	T	60°F	16°C
Process Water Connection:		1/4" FNPT	1/4" FNPT

Electrical

Std. Elect. Requirements:	V	230/460V	230/400V
	Ph	3 Ph	3 Ph
	Hz	60 Hz	50 Hz
	Amp	6.4/3.2 A	6.4/3.2 A
	HP	2 Hp	1.5 Kw

Note: All others subject to approval by Baader-Johnson

Mechanical

Shackle Length:	Min	26"	661 mm
	Max	34"	864 mm
Track Height Min	Min	70"	1778 mm
	Max	80"	2032 mm
Shackle Types:		Stainless Steel Picking Shackles	

Note: All others subject to approval by Baader-Johnson

Note: All rigid shackles to be mounted with neutral clips or clips pointing away from the machine.

Track Types:	T-rail (50mm)	
	I-Beam (3")	
	Round Pipe 1-1/4" Sch 80	42 x 5mm

Note: All others subject to approval by Baader-Johnson

Chain Types:	Log chain (1")
	Log chain (1-1/2")
	X 348

Note: All others subject to approval by Baader-Johnson

Note: Chain stretch not to exceed 4%

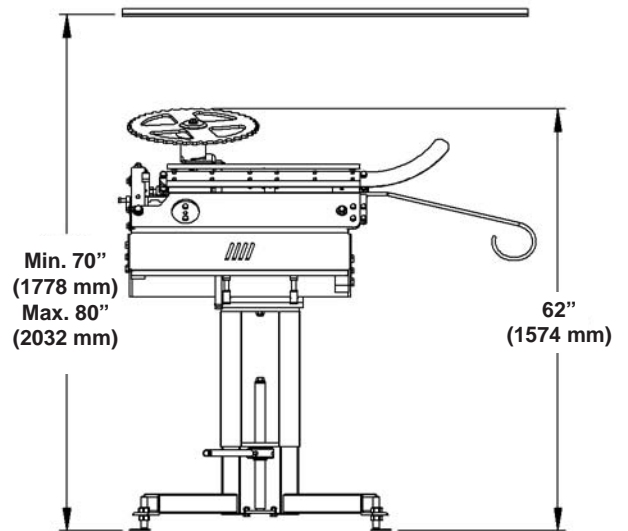
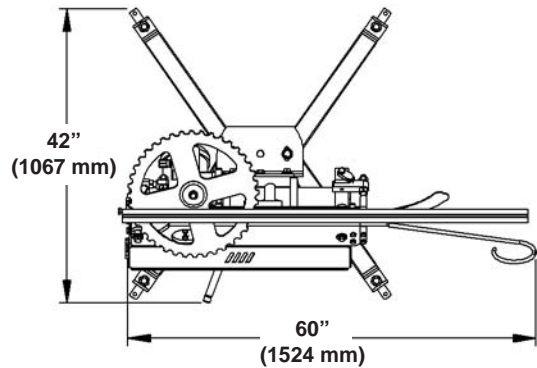

Illustrations and dimensions are approximate and not binding. Subject to design changes in the interest of technical progress. Actual scope of supply is specified in our quotations and order confirmations and may differ from descriptions and photos in this leaflet.

Attention!

For the illustration of technical details the safety devices and protection mechanisms are partly not shown in operative condition. When operating the machine, all corresponding devices and instructions referring to the safety of the machine must be utilized and/or observed. (Protective panels and safety guards removed for photograph)



Johnson Food Equipment, Inc.
 Member of the BAADER Group
 2955 Fairfax Trafficway Kansas City, KS 66115
 Tel: 913-621-3366 Fax: 913-621-1729
 Email: sales@baader-johnson.com
 Web Site: www.baader-johnson.com
 800-288-3434 U.S. & Canada